

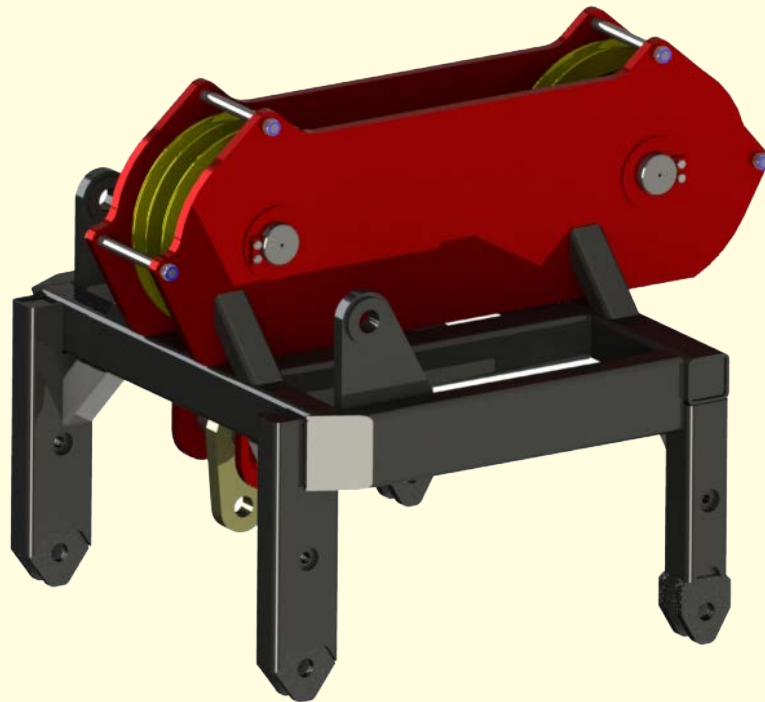

PILECO INC.

Parts Manual

**8000414 U-42 Single Line Head Block
with 3 Sheaves
(2 Part)
Parts Manual**



U-42 SINGLE LINE HEAD BLOCK WITH 3 SHEEVES

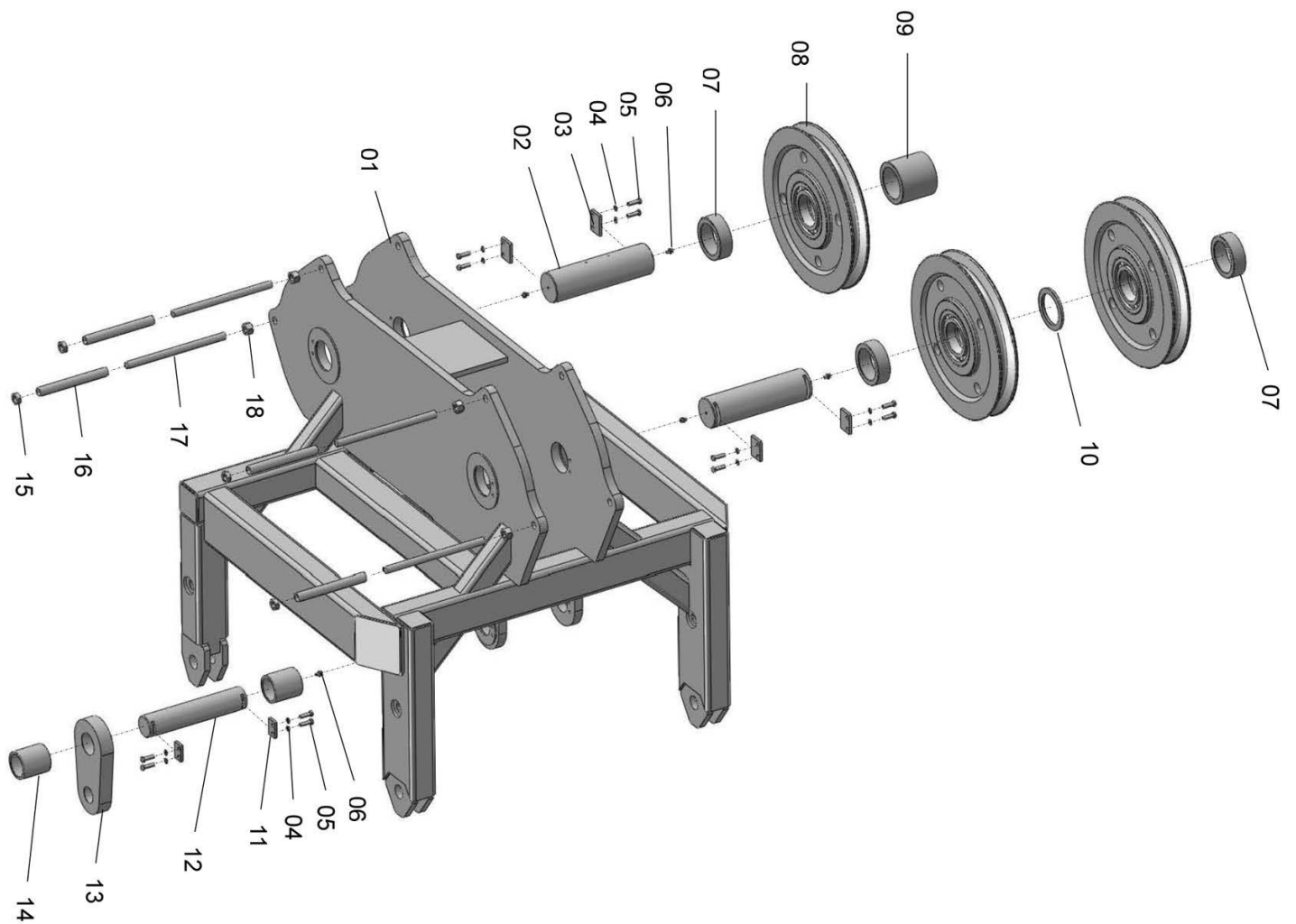

U-42 SINGLE LINE HEAD BLOCK WITH 3 SHEEVES

ITEM NO.	PART NUMBER	DESCRIPTION	QTY.
1	321001	U-42 Head block 1 Line 2 Part welded frame	1
2	321002	Rope Pulley Shaft	2
3	321003	Holding plate	4
4	260928	Lock washer, M12	12
5	321004	Bolt hex, M12x40	12
6	90791	Grease nipple, M10x1	5
7	321005	Spacer	3
8	220916	Rope pulley	3
9	321006	Spacer	1
10	321007	Spacing ring	1
11	321008	Holding plate	2
12	321009	Rope Pulley Shaft	1
13	321010	Shackle	1
14	321011	Spacer	2
15	321012	1"-8 Nut, nylon	4
16	321013	Roller tube	4
17	321014	1"-8 Stud	4
18	321016	1"-8 Nut	4

Visual Inspections

1. All equipment shall be checked every 6 months for wear and cracks
2. Check all welds for cracking and fatigue
3. Bearings shall be inspected for unusual wear and replaced if needed
4. Hoses shall be replaced if cracks or leakage occur

**RECOMMENDED LUBRICANT:
MOBILITH SHC 220 GREASE**

LUBRICATION MAINTENANCE SCHEDULE:	DAILY	6 MONTHS	ANNUALLY
GREASE ALL SHEAVES	•		
REPACKING OF BEARINGS			•

REPACKING OF BEARINGS MUST BE DONE MANUALLY. PLEASE REFER TO SKF FOR PROPER PACKING OF BEARINGS.