

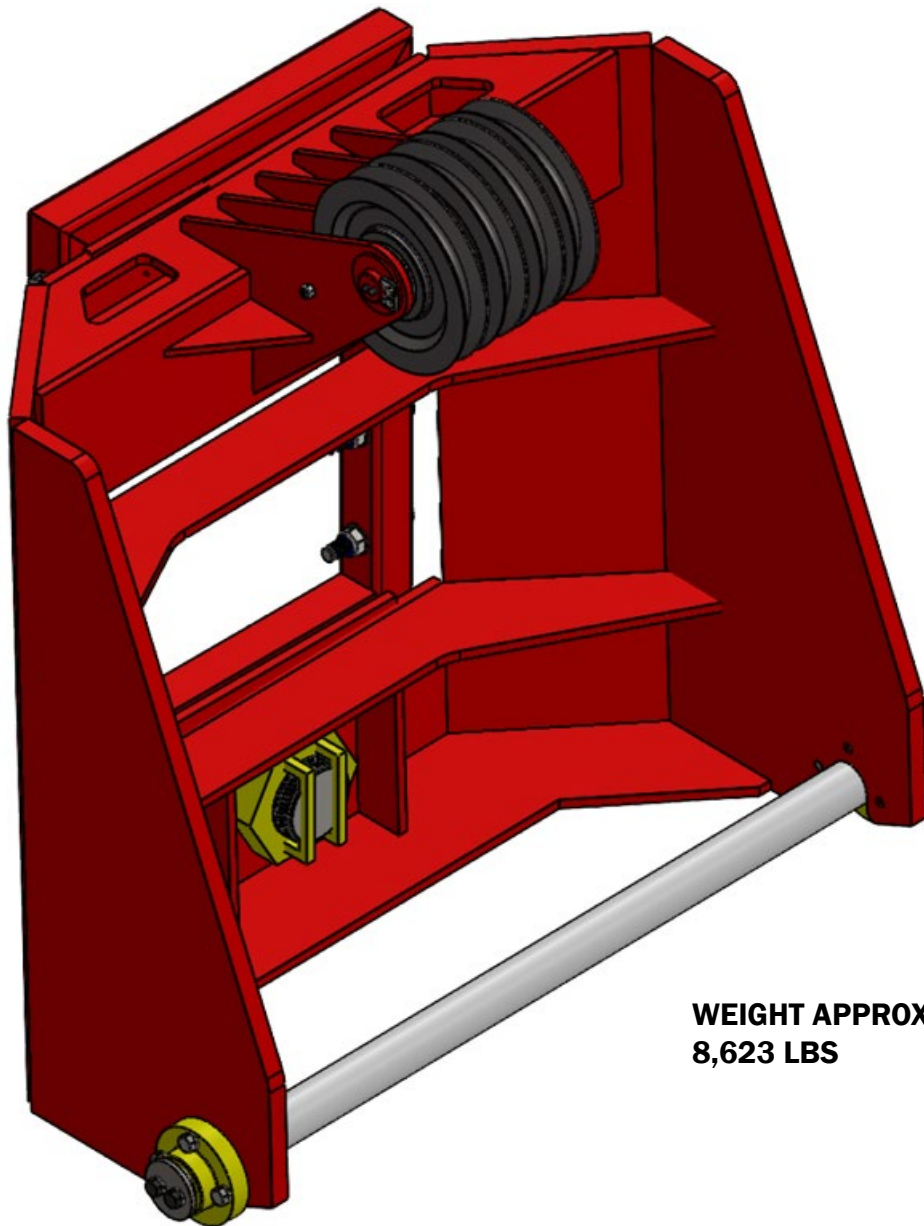

PILECO INC.

Parts Manual

(8000829)
#22 MANITOWOC BOOM POINT
CONNECTOR FOR U-32 FIXED LEADS
Parts Manual



WEIGHT APPROX:
8,623 LBS

#22 MANITOWOC BOOM POINT CONNECTOR FOR U-32 FIXED LEADS

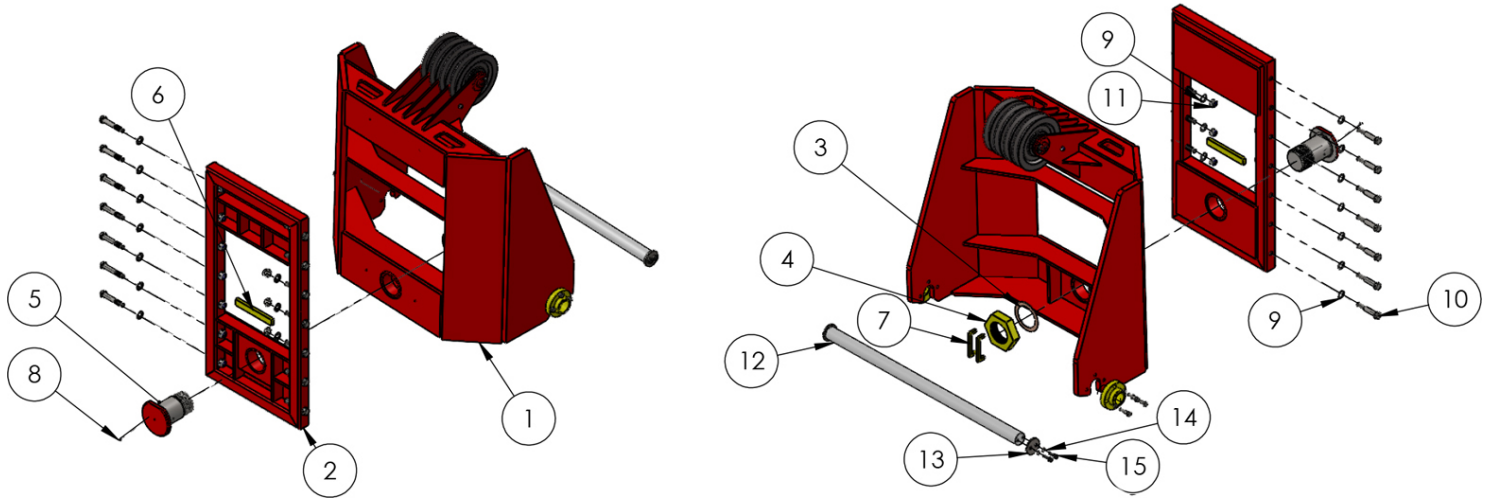

NOTES:

1. FASTENERS TO BE SHIPPED SEPARATELY
2. BOLTS TO BE TORQUED TO 100 FT LBS TO ENGAGE NYLON LOCKNUT FULLY
3. SLED TO BE CENTERED BETWEEN RAILS WHEN INSTALLED

ITEM NO.	PART NUMBER	DESCRIPTION	QTY.
1	8000547	#22 BOOM POINT CONNECTOR COMPLETE	1
2	8000595	U-32 VERTICAL TRAVEL BOOM POINT CONNECTOR SLED, 7 HOLES	1
3	8000830	BRONZE WASHER	1
4	8000831	HEX NUT	1
5	8000441	PIN	1
6	8000832	LOCKING PLATE	1
7	06195	HEX NUT LOCKING PLATE	2
8	90791	GREASE NIPPLE M10 X 1	1
9	8000477	1 1/2 FLATWASHER	28
10	8004626	1 1/2-6 X 9 HEX HEAD CAP SCREW GR 8	14
11	8004664	1 1/2-6 NYLON INSERT LOCKNUT	14
12	CUSTOMER PROVIDED	MANITOWOC #22 BOOM POINT CONNECTOR PIN LENGTH	1
13	8006505	MANITOWOC BOOM POINT LOCKING PIN PLATE	2
14	8000639	1 LOCKWASHER	4
15	8001162	1-8 X 3 HEX HEAD CAP SCREW GR 8	4

#22 MANITOWOC BOOM POINT CONNECTOR FOR U-32 FIXED LEADS

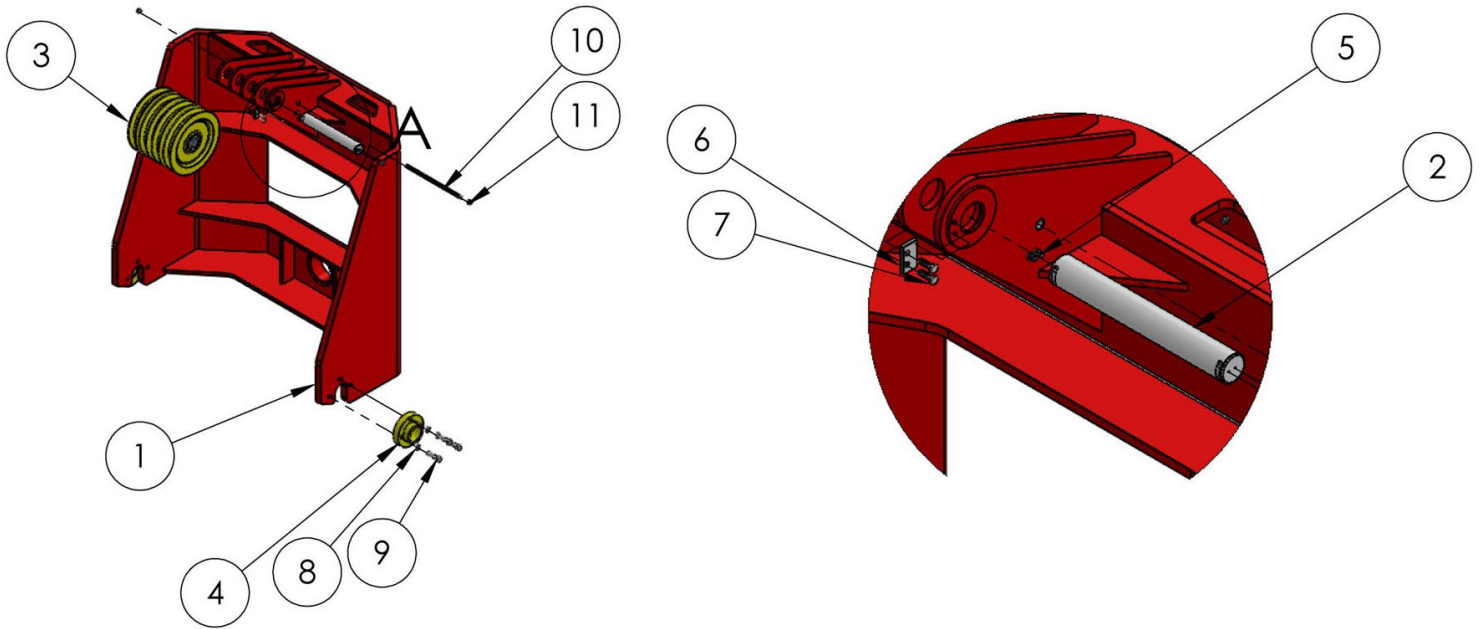

ITEM NO.	PART NUMBER	DESCRIPTION	QTY.
1	8000549	BOOM POINT CONNECTOR ASSEMBLY	1
2	8000833	SHAFT	1
3	303011	SHEAVE WITH BEARING	4
4	8000835	LOCKING RING	2
5	90791	GREASE NIPPLE M10 X 1	8
6	8000836	PLATE	2
7	8000837	12MM-1.75 X 40 HEX HEAD CAPSCREW	4
8	8000639	1" LOCKWASHER	6
9	8001161	1-8 X 4 HEX HEAD CAPSCREW GR8	6
10	8000840	3/4-10 ALL THREAD ROD	1
11	8000841	3/4-10 NYLON INSERT LOCKNUT	2

FIELD BOOM POINT ASSEMBLY

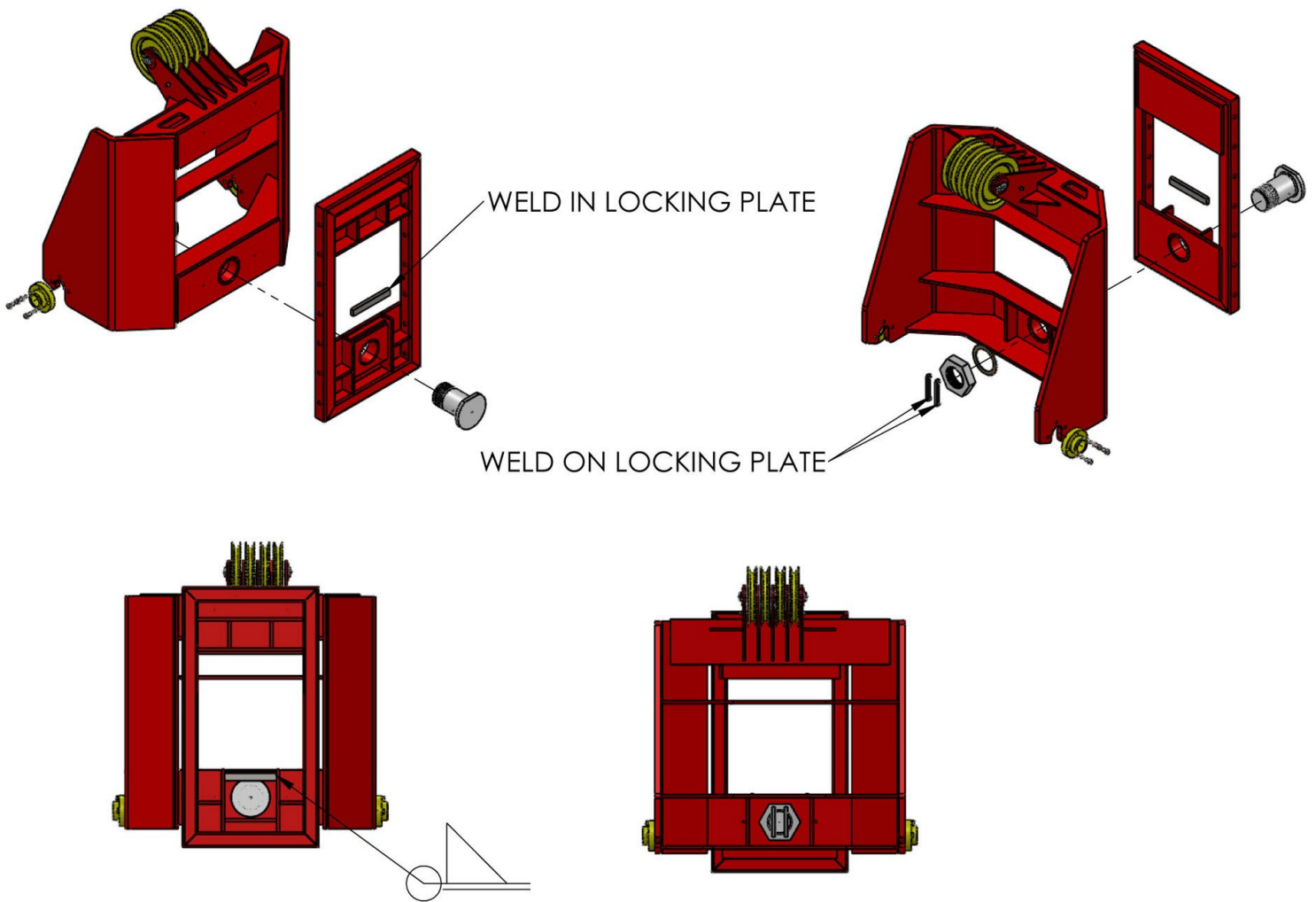

LUBRICATION POINTS

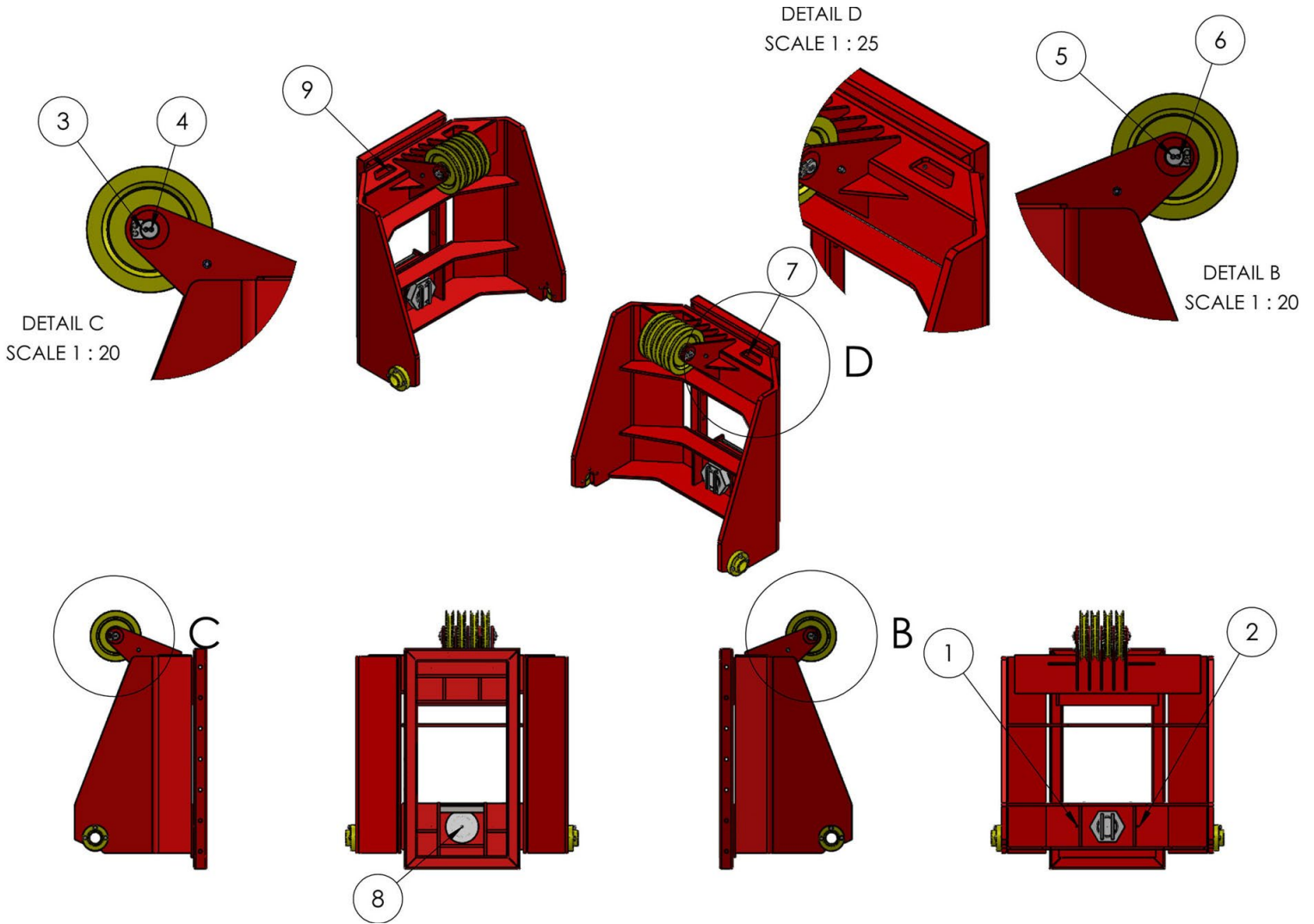

#22 MANITOWOC BOOM POINT CONNECTOR FOR U-32 FIXED LEADS

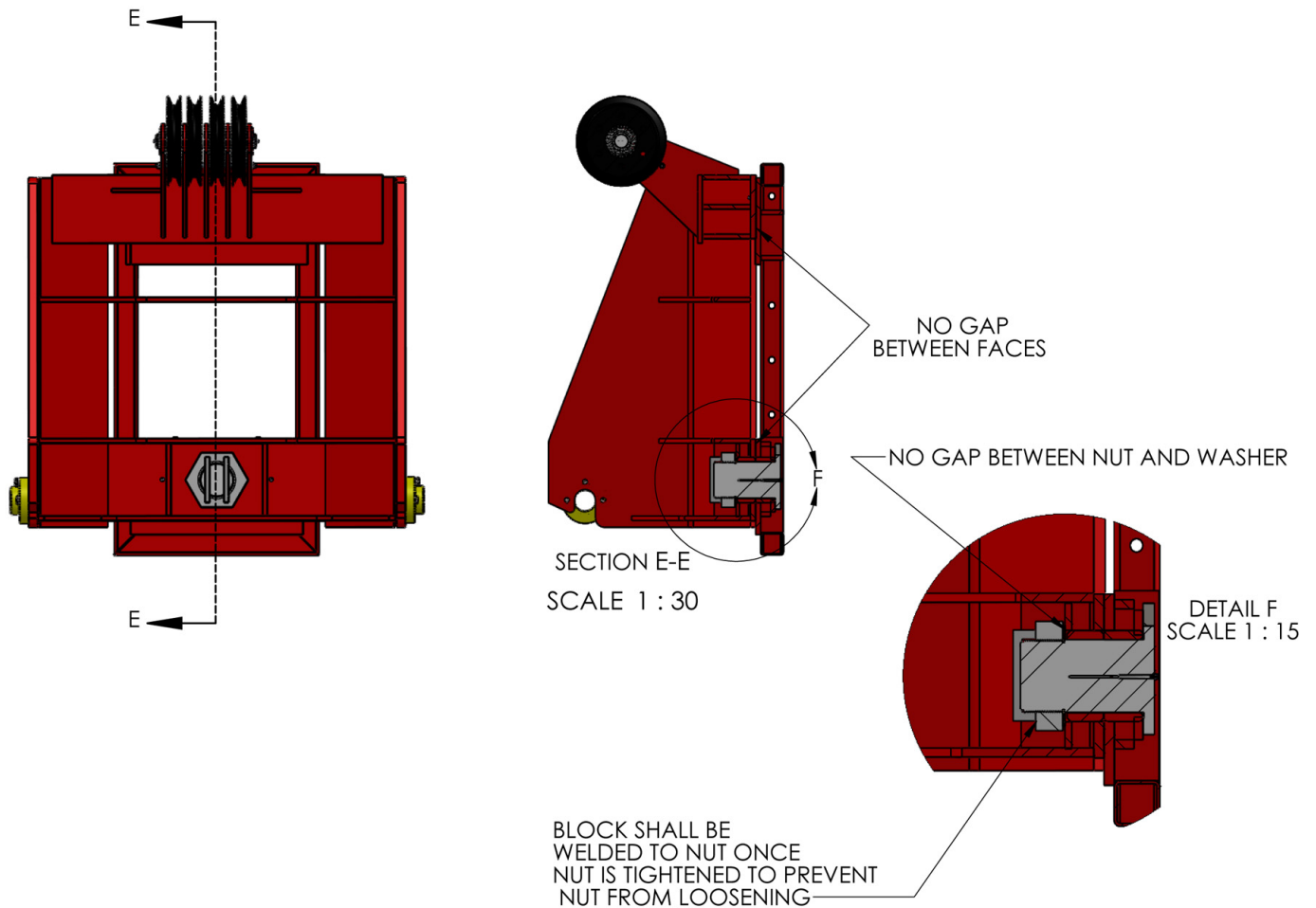

NOTE:

1. GAP BETWEEN BOOM POINT CONNECTOR AND SLED SHALL BE INSPECTED ON SEMI ANNUAL BASIS. TO INSURE NO GAPPING BETWEEN SURFACES.
2. PIN AND NUT THREADS SHALL BE INSPECTED FOR ANY DEFORMATIES AND REPLACED IF ANY DAMAGE TO PIN AND NUT HAS OCCURED DUE TO FATIGUE OR STRESS.

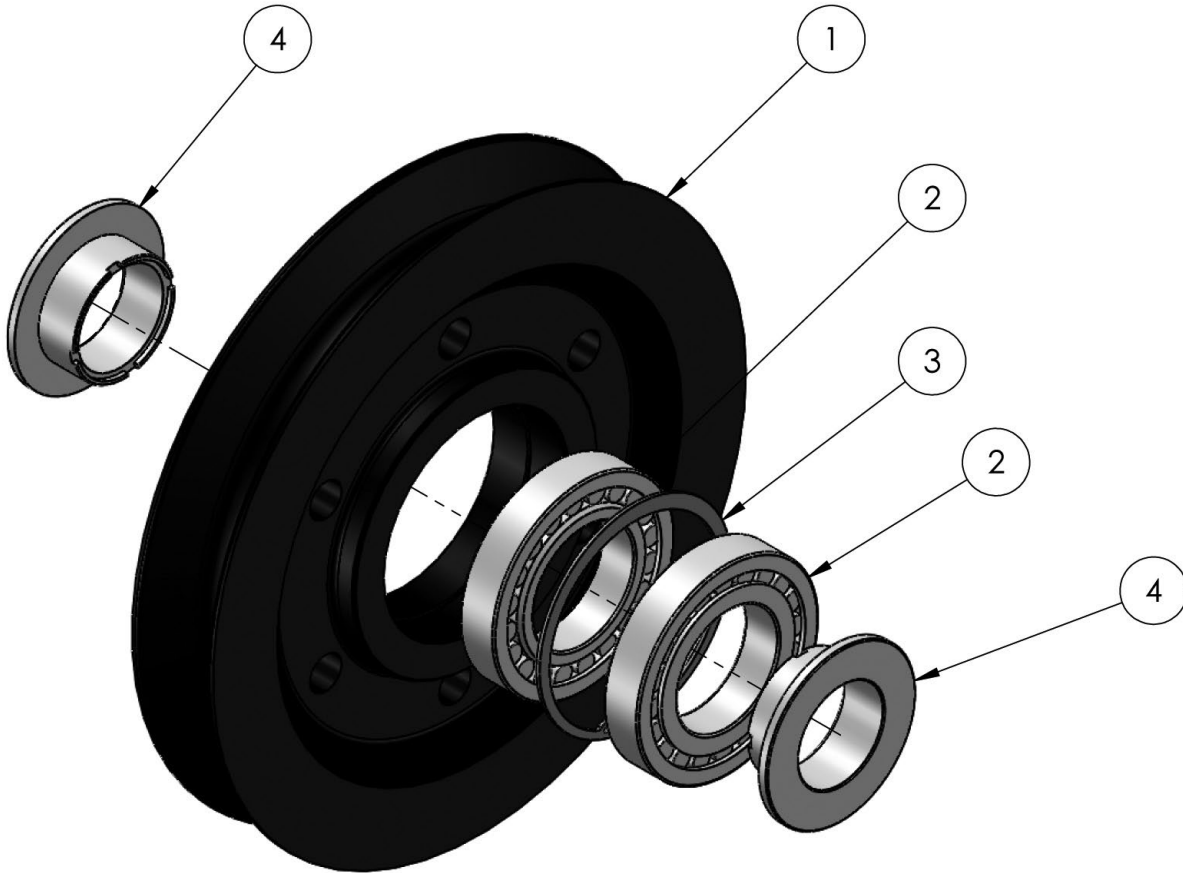
SHEEVE WITH BEARING

ITEM NO.	PART NUMBER	DESCRIPTION	QTY.
1	303012	SHEAVE BLANK	1
2	205043	NJ219E BEARING	2
3	205044	170 X 3 CIRCLIP	1
4	303013	BEARING SLEEVE	2

LUBRICATION MAINTENANCE
VISUAL INSPECTIONS:

1. All equipment shall be checked every 6 months for wear and cracks
2. Check all welds for cracking and fatigue
3. Bearings shall be inspected for unusual wear and replaced if needed

**RECOMMENDED LUBRICANT:
MOBILITH SHC 220 GREASE**

LUBRICATION MAINTENANCE SCHEDULE:	DAILY	6 MONTHS	ANNUALLY
ALL LUBRICATION LOCATION	•		
REPACKING OF SHEAVE BEARINGS			•
REPACKING OF REVOLVING FAIRLEAD BEARINGS			•

REPACKING OF BEARINGS MUST BE DONE MANUALLY. PLEASE REFER TO SKF FOR PROPER PACKING OF BEARINGS.